



# DUCTILE RUPTURE AND INSTABILITIES

## PAST AND CURRENT APPLICATIONS TO LANDING GEAR (LG) STRUCTURES

N. Antoni, 24/01/2019



# CONTENTS

## 1. Introduction

- 1.1 General Certification Requirements
- 1.2 Typical LG Applications
- 1.3 Historical Approaches of Strength Design Criteria

## 2. Current Approach for LG Structures

- 2.1 Overview of Strength Analysis Methods
- 2.2 Structural Allowables Derivation
  - 2.2.1. Bending of round tubes
  - 2.2.2. Torsion of round tubes
  - 2.2.3. Lugs

## 3. Perspectives: Towards Unified Rupture and Instabilities Criteria

- 3.1 Enhancement of Structural Allowables Derivation
- 3.2 Virtual Testing

# 1

## INTRODUCTION

1.1 GENERAL CERTIFICATION REQUIREMENTS

1.2 TYPICAL LG APPLICATIONS

1.3 HISTORICAL APPROACHES OF STRENGTH DESIGN CRITERIA



# 1. Introduction

## 1.1 General Certification Requirements

- **FAR 25 and CS 25: Certification by “Analysis Supported by Test Evidence”**

CS 25.307 requires compliance for each critical loading condition. Compliance can be shown by analysis supported by previous test evidence, analysis supported by new test evidence or by test only. As compliance by test only is impractical in most cases, a large portion of the substantiating data will be based on analysis.

- **Limit Loads (= Maximum loads expected in service)**

- > **No detrimental permanent deformation** up to limit loads (e.g. residual tensile stress after limit load release)
- > Deformation should not interfere with safe operation (e.g. disassembly/reassembly of components at overhaul)
- > No detrimental impact on static and fatigue strength

- **Ultimate Loads (= Limit Loads multiplied by a prescribed safety factor equal to 1.5)**

- > Support ultimate loads **without fracture** (for at least 3 seconds on test)

- **Fatigue Loads (= In-service common loads)**

- > **No detectable fatigue crack** (safe life concept) for a given target in lifetime multiplied by a prescribed scatter factor

- **Particular Risk Analyses**

- > Crashworthiness
- > Bird impact, Wheel and Tyre impact



# 1. Introduction

## 1.2 Typical LG Applications

- **Ground Load Spectrum: a great variety of load cases!**

➤ Simple applied ground load spectrum for a single typical flight

- ◆ **Static – Taxi out – Turning – Engine Run Up – Take Off** – [Retraction – Lowering] – **Landing – Braking – Turning – Taxi in – Static**  
Take Off Weight (Short, Medium, Long Range) Landing Weight
- ◆ **Landing** phase is composed of the following load cases: Spin-Up – Spring Back – Maximum Vertical
- ◆ **Taxi in/out manoeuvres** are composed of Taxi Bump load cases

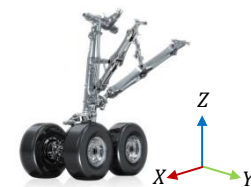
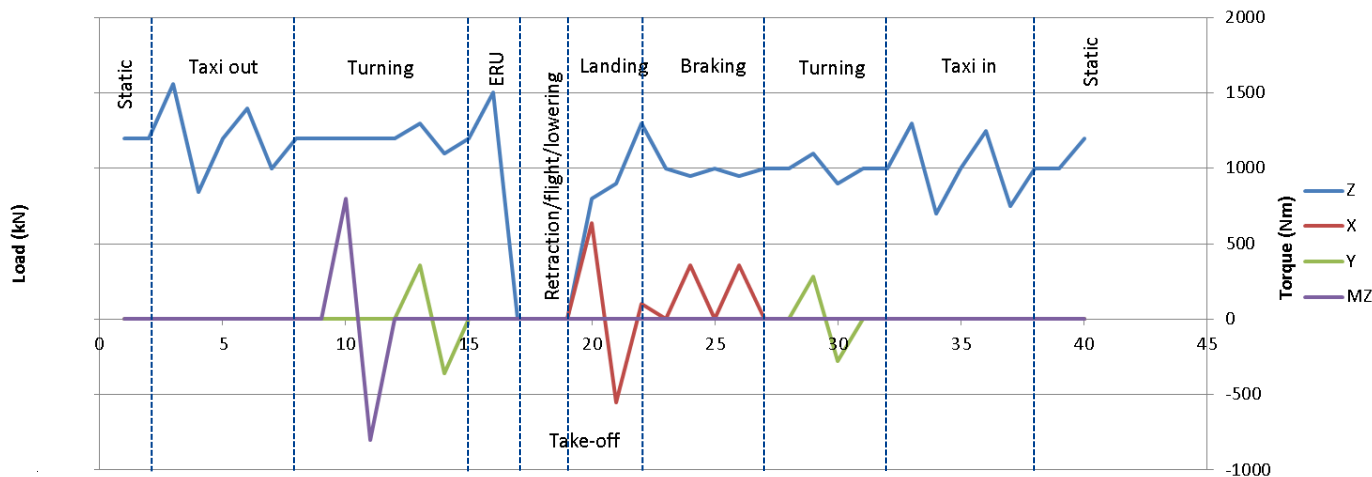

# 1. Introduction

## 1.2 Typical LG Applications

- **Rupture and Instabilities Criteria**

> Multiple possible failure modes!

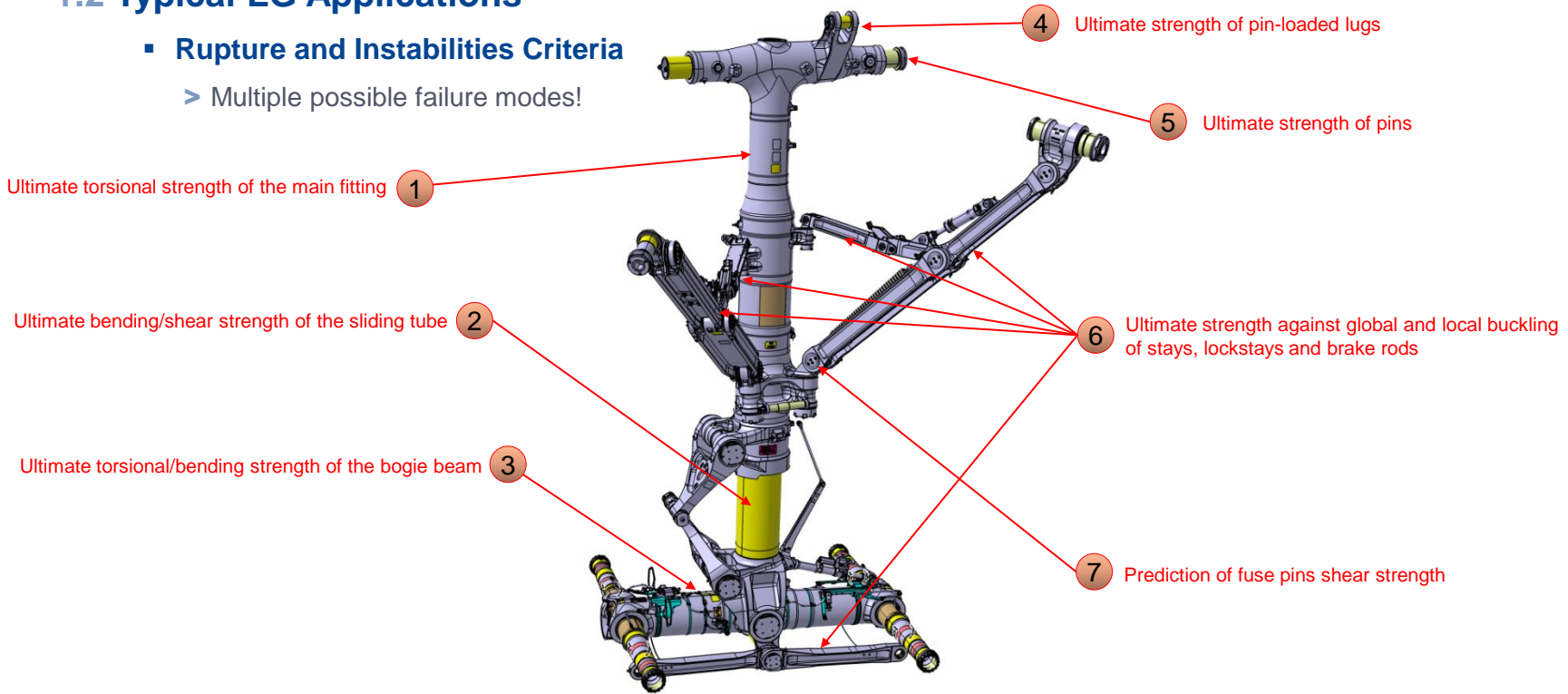

# 1. Introduction

## 1.3 Historical Approaches of Strength Design Criteria

### ▪ Example 1: Combined Axial-Torsion

- Thin-walled cylinders assumption
- **Applicability domain** of charts not well identified from a material point of view
  - ◆ Risky extension to other materials!

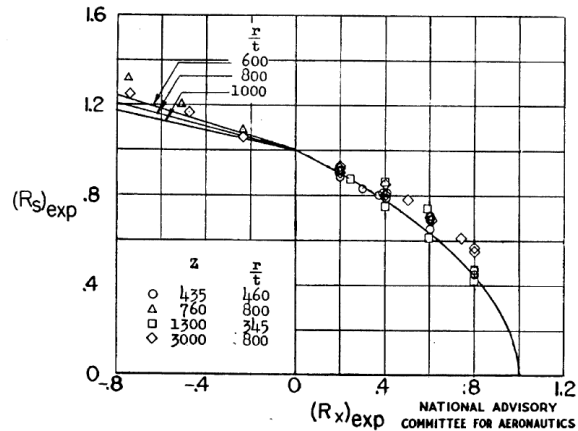

Figure 5.- Comparison of empirical interaction curve with test data presented by Bruhn.

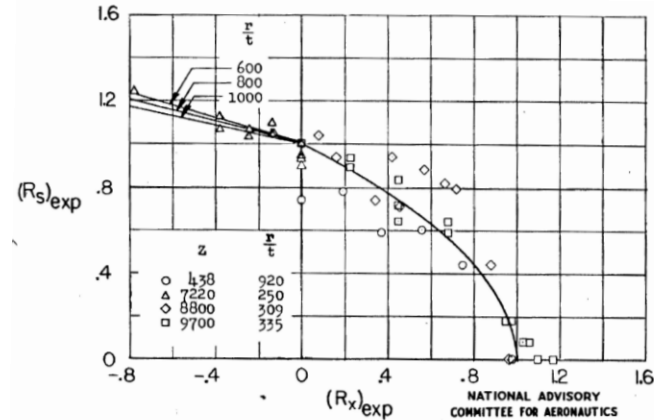

Figure 6.- Comparison of empirical interaction curve with test data presented by Bridget.

- NACA (1947) -



# 1. Introduction

## 1.3 Historical Approaches of Strength Design Criteria

- **Example 2: Lugs (transverse loading)**

- **Applicability domain** of charts not well identified from a material point of view
- No lug design curve available for titanium alloys

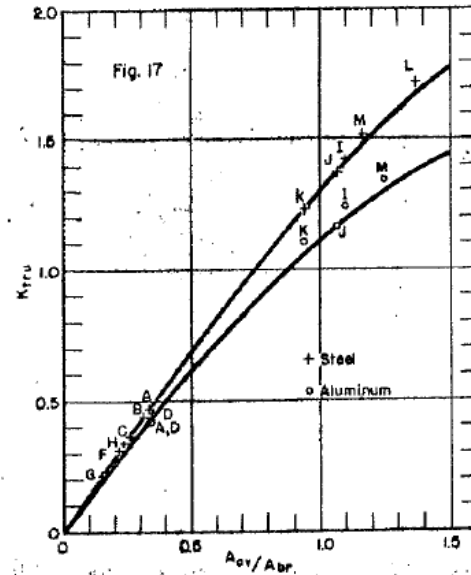
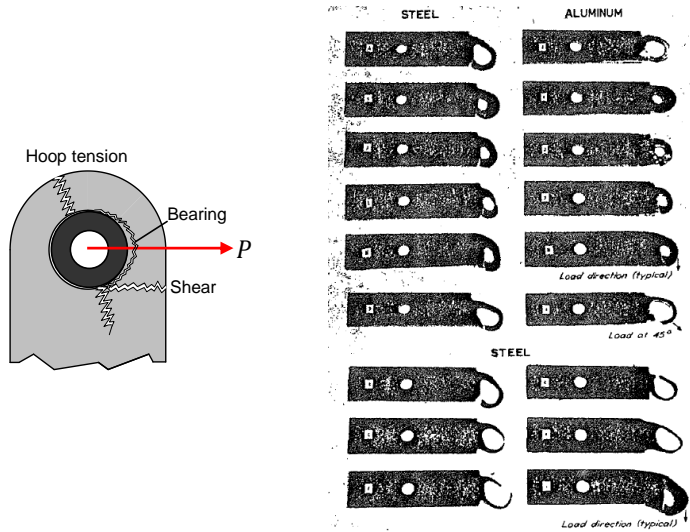

- Melcon and Hoblit (1953) -



# 2

## CURRENT APPROACH FOR LG STRUCTURES

2.1 OVERVIEW OF STRENGTH  
ANALYSIS METHODS

2.2 STRUCTURAL ALLOWABLES  
DERIVATION



## 2. Current Approach for LG Structures

### 2.1 Overview of Strength Analysis Methods

- **Classical analysis methods are based on analytical (hand) calculations of forces and stress components**
  - > **Recognized analysis methods** by certification authorities (acceptable means of compliance)
    - ♦ Importance of the **applicability domain!** (geometry, material and/or loading)
  - > Opposed to numerical approaches (e.g. finite element methods) only accepted when validated by understood testing

CS 25.307 requires compliance for each critical loading condition. Compliance can be shown by analysis supported by previous test evidence, analysis supported by new test evidence or by test only. As compliance by test only is impractical in most cases, a large portion of the substantiating data will be based on analysis.

There are a number of standard engineering methods and formulas which are known to produce acceptable, often conservative results especially for structures where load paths are well defined. Those standard methods and formulas, applied with a good understanding of their limitations, are considered reliable analyses when showing compliance with CS 25.307. Conservative assumptions may be considered in assessing whether or not an analysis may be accepted without test substantiation.

The application of methods such as Finite Element Method or engineering formulas to complex structures in modern aircraft is considered reliable only when validated by full scale tests (ground and/or flight tests). Experience relevant to the product in the utilisation of such methods should be considered.

➡ Classical Analysis Approach

➡ FEA Approach

## 2. Current Approach for LG Structures

### 2.1 Overview of Strength Analysis Methods

#### Classical analysis method vs FE method

- > Classical analysis should be **preferred** over FEA whenever possible
- > If non-linear FEA is considered:
  - ◆ FE model should be **fully validated by tests**
  - ◆ Only **internal forces extracted** from FEA may be used but as input to classical analysis

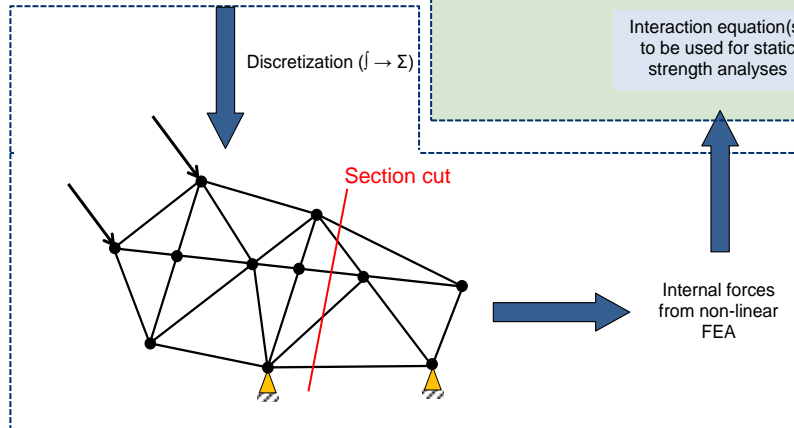
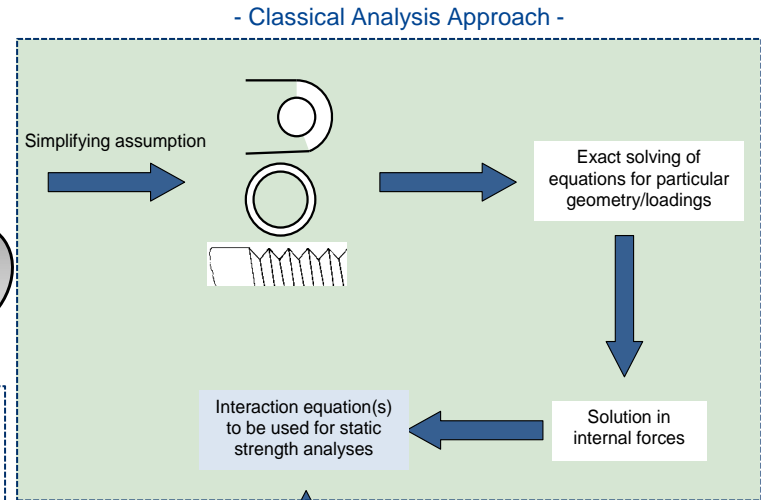
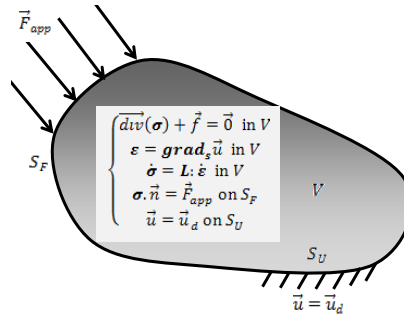

## 2. Current Approach for LG Structures

### 2.1 Overview of Strength Analysis Methods

- **Margin of Safety (MoS) or Reserve Factor (RF)**

- > **Margins of Safety** for structural components under **Limit and Ultimate Loads**

- ♦ The usual definition of the **margin of safety** is

$$MoS = \frac{1}{kU} - 1$$

- $U = \frac{P_{app}}{P_{all}}$  or  $U = \frac{\sigma_{app}}{\sigma_{all}}$  denotes the **utilization factor**
      - $P_{app}$  (respectively  $\sigma_{app}$ ) denotes the applied load (resp. applied stress) at limit or ultimate condition
      - $P_{all}$  (respectively  $\sigma_{all}$ ) denotes the limit or ultimate allowable load (resp. allowable stress)
      - $k$  denotes any special factor required for design (casting factor, fitting factor, etc)
    - ♦ The notion of **reserve factor** is also often used:

$$RF = MoS + 1$$

- ♦ It is important to note that the utilization factor (and therefore the margin of safety) is to be calculated based on **quantities that are proportional to the loads** (i.e.  $\sigma = \lambda P$ )

- > Optimize global geometry/materials for minimum weight, maintaining acceptable margins of safety (i.e.  $MoS \geq 0$  or  $RF \geq 1$ )

## 2. Current Approach for LG Structures

### 2.1 Overview of Strength Analysis Methods

#### ▪ Interaction Equations (ultimate condition)

##### > Generalized utilization factor

- Note that equation  $U = 1$  is equivalent to a **fracture criterion**. A generalized fracture criterion (interaction equation) to account for **multiaxiality** can be obtained through the derivation of a generalized utilization factor ( $\beta \geq 1$ )

$$U = \left( \sum_{i=1}^6 \left( \frac{F_i(P_{app})}{F_{i\ all}} \right)^\beta \right)^{1/\beta} \quad \text{or} \quad U = \left( \sum_{i=1}^6 \left( \frac{\sigma_{i\ app}}{\sigma_{i\ all}} \right)^\beta \right)^{1/\beta}$$

- where  $\{F_i\}_{1 \leq i \leq 6}$  are internal forces components (e.g.  $N, M_b, T, M_t$ ) and  $\{F_{i\ all}\}_{1 \leq i \leq 6}$  are associated allowable forces (e.g.  $N_u, M_{bu}, T_u, M_{tu}$ )
- where  $\{\sigma_{i\ app}\}_{1 \leq i \leq 6}$  are stress components (e.g.  $\sigma_n, \sigma_b, \sigma_s, \sigma_{st}$ ) and  $\{\sigma_{i\ all}\}_{1 \leq i \leq 6}$  are associated allowable stresses (e.g.  $F_{tu}, F_{bu}, F_{su}, F_{stu}$ )

##### > Common interaction equations (in particular for static strength analysis of sections)

Type of loading	Interaction equation	Utilization ratios
Axial-Bending	$U = U_n + U_b$	$U_n = \frac{\sigma_n}{F_{tu}}, U_b = \frac{\sigma_b}{F_{bu}}$
Axial-Bending-Shear	$U = U_n + \sqrt{U_b^2 + U_s^2}$	$U_n = \frac{\sigma_n}{F_{tu}}, U_b = \frac{\sigma_b}{F_{bu}}, U_s = \frac{\sigma_s}{F_{su}}$
Axial-Bending-Shear-Torsion	$U = U_n + \sqrt{U_b^2 + (U_s + U_{st})^2}$	$U_n = \frac{\sigma_n}{F_{tu}}, U_b = \frac{\sigma_b}{F_{bu}}, U_s = \frac{\sigma_s}{F_{su}}, U_{st} = \frac{\sigma_{st}}{F_{stu}}$
Oblique Loading for Lugs	$U = (U_{ax}^{1.6} + U_{tr}^{1.6})^{0.625}$	$U_{ax} = \frac{P_{ax}}{P_{axu}}, U_{tr} = \frac{P_{tr}}{P_{tru}}$

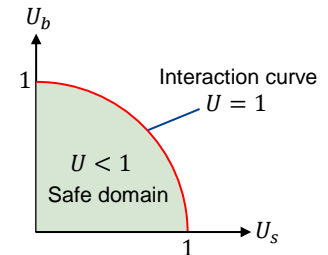

## 2. Current Approach for LG Structures

### 2.2 Structural Allowables Derivation

#### ▪ Bending Modulus of Rupture $F_{bu}$ of Round Tubes (1/5)

##### > Overview

>  $F_{bu}$  is a **fictitious** stress allowable that represents the “**elastic**” bending stress level at which the bending fracture of the tube is predicted:

$$F_{bu} = \frac{c}{I} M_{b\text{ ult}}$$

- $c = D/2$  is the distance from the neutral axis to the outermost fibre
- $I$  is second moment of area
- $M_{b\text{ ult}}$  is the ultimate moment, that is, the internal moment level that results in the bending fracture of the tube

> As  $F_{bu}$  is calculated from the elastic stress equation, a margin calculated from this value and the bending stress is equivalent to calculating the margin using the applied and ultimate internal moments:

$$MoS = \frac{F_{bu}}{\sigma_b} - 1 = \frac{M_{b\text{ ult}}}{M_b} - 1$$

> The calculation of  $M_{b\text{ ult}}$  depends upon the bending fracture mode. One distinguishes **two different bending fracture modes**:

- ♦ **Fracture mode for solid cylinders** ( $D/t=2$ ): The cross-section remains circular (no ovalization), the fracture occurs when the maximum bending stress reaches the material ultimate strength (local fracture criterion).
- ♦ **Fracture mode for hollow cylinders** ( $D/t>2$ ): The cross-section ovalizes as the bending curvature is increased. The fracture occurs when the maximum bending moment is reached for an equilibrium state in the elastic-plastic domain.

## 2. Current Approach for LG Structures

### 2.2 Structural Allowables Derivation

#### ▪ Bending Modulus of Rupture $F_{bu}$ of Round Tubes (2/5)

##### > Solid Cylinder ( $D/t = 2$ ):

- ♦ The ultimate moment  $M_{b\text{ult}}$  is derived using the **Cozzone approach**
- ♦ The stress distribution in the cross-section is idealized as linearly varying between a fictitious neutral axis stress  $F_{ou}$  and  $F_m = F_{tu}$  at the outer fibre
- ♦ The final bending moment is found by integrating the stress on the cross-section

$$M_{b\text{ult}} = \int_S \left[ F_{ou} + \left( \frac{F_m - F_{ou}}{c} \right) z \right] z dS = F_{tu} \frac{I}{c} + F_{ou} \left( 2Q - \frac{I}{c} \right)$$

- ♦ The bending strength is thus:

$$F_{bu} = F_{tu} + F_{ou}(k - 1)$$

$$k = \frac{2Qc}{I}$$

$$I = \int_S z^2 dS = \frac{\pi}{64} (D^4 - (D - 2t)^4)$$

$$Q = \int_{S^+} z dS = \frac{1}{12} (D^3 - (D - 2t)^3)$$

- ♦ The neutral axis stress  $F_{ou}$  is found by equating the internal moment of the idealized stress distribution with the internal moment of the actual material stress-strain curve. Let  $W_{\text{actual}} = \int_0^{\epsilon_u} \sigma \epsilon d\epsilon$

$$F_{ou} = \frac{6}{\epsilon_u^2} \left( W_{\text{actual}} - \frac{\epsilon_u^2}{3} F_{tu} \right)$$

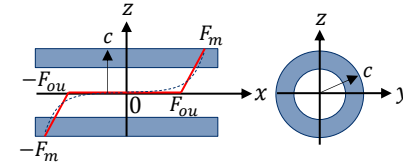
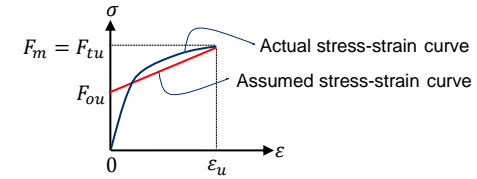



## 2. Current Approach for LG Structures

### 2.2 Structural Allowables Derivation

#### ▪ Bending Modulus of Rupture $F_{bu}$ of Round Tubes (3/5)

##### > Hollow Cylinder ( $D/t > 2$ ):

- ♦ As a tube deforms plastically, the stress profile becomes non-linear and the cross-section ovalizes
- ♦ The value of  $M_{b\,ult}$  is derived using the method of calculation published by CLIFFORD S. ADES in the paper « Bending Strength of Tubing in the Plastic Range » (1957), extension of Brazier method (1927)
- ♦ The ADES paper is referenced in the MMPDS. The paper method of calculation was used to produce the BMoR charts published in the MMPDS
- ♦ The section is discretized to calculate the total potential energy and bending moment at a given elliptical shape (semi-major axis,  $a$ )
- ♦ The **equilibrium position** at a given longitudinal curvature is obtained by **minimizing the energy across a range of semi-major axes**, while the **maximum moment** that can be carried at a given  $D/t$  is found by **maximizing the moment across a range of curvatures**

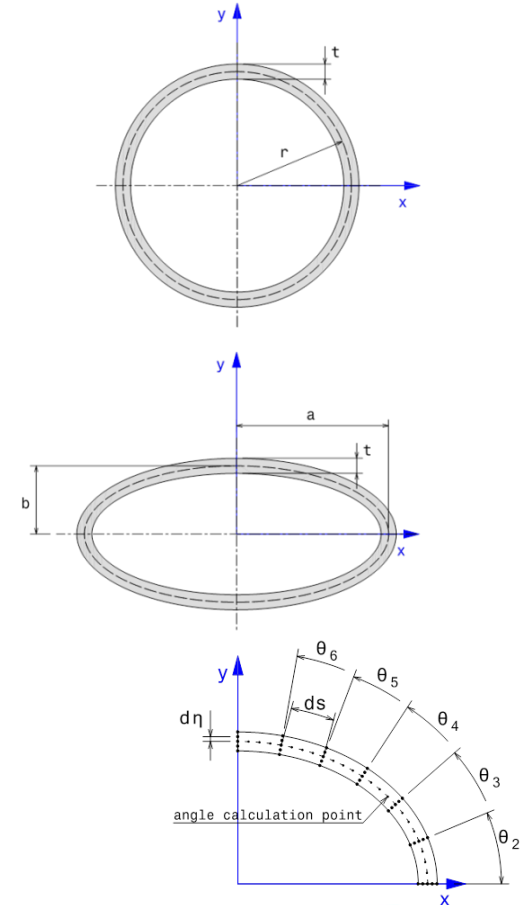

## 2. Current Approach for LG Structures

### 2.2 Structural Allowables Derivation

- Bending Modulus of Rupture  $F_{bu}$  of Round Tubes (4/5)

> Hollow Cylinder ( $D/t > 2$ ):

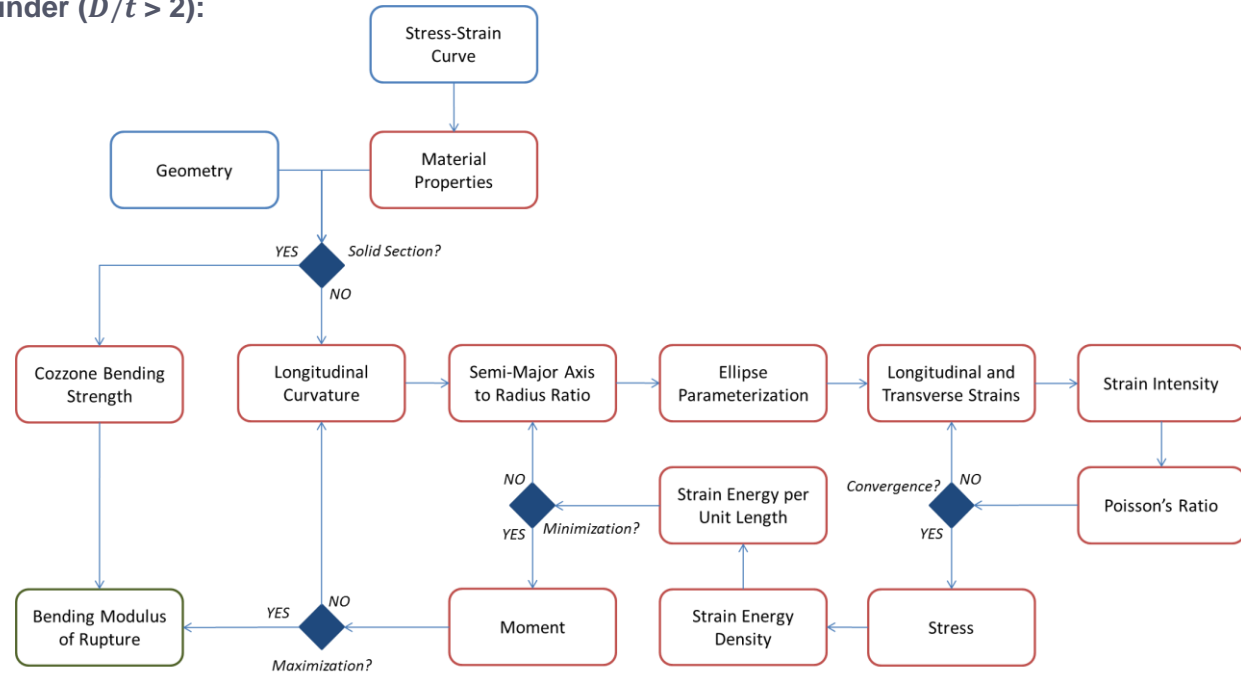

## 2. Current Approach for LG Structures

### 2.2 Structural Allowables Derivation

#### ▪ Bending Modulus of Rupture $F_{bu}$ of Round Tubes (5/5)

##### > Method assumptions and example of BMoR charts:

- ♦ Thin shell theory involving the effects of large deflections and imperfections in the elastic-plastic domain but small strains,
- ♦ During ovalization, planes initially normal to the midsurface remain normal
- ♦ The tube experiences pure bending under prescribed rotation, with no consideration of the end conditions
- ♦ The material is isotropic and assumed to have identical stress-strain curves in tension and compression (the neutral axis remains at the axis of symmetry)
- ♦ Ovalization is assumed perfectly symmetric without accounting for local buckling in the compressive area for large  $D/t$
- ♦ The Poisson's ratio is constant below the proportional limit and a function of the strain above, calculated assuming zero plastic dilation

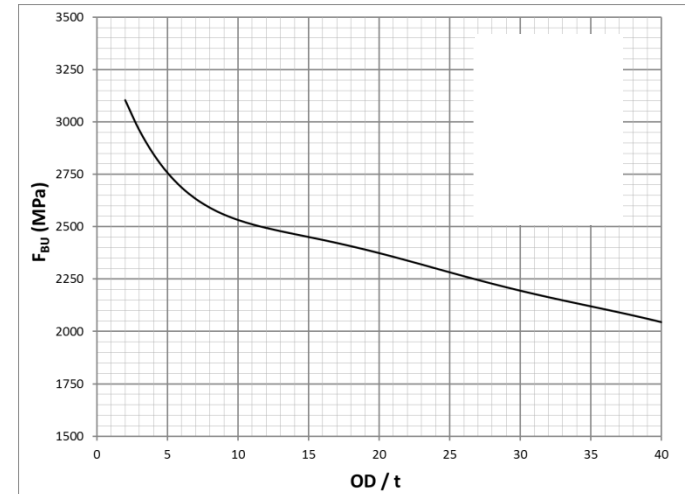
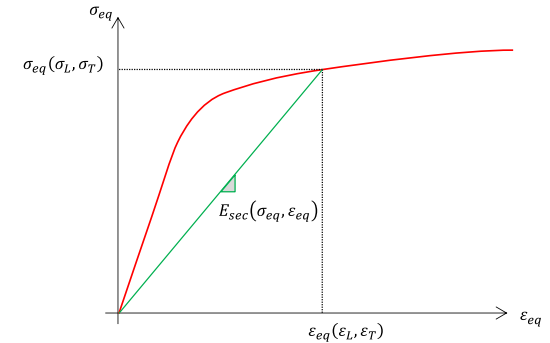

$$F_{bu} = A \left(\frac{D}{t}\right)^6 + B \left(\frac{D}{t}\right)^5 + C \left(\frac{D}{t}\right)^4 + D \left(\frac{D}{t}\right)^3 + E \left(\frac{D}{t}\right)^2 + F \left(\frac{D}{t}\right) + K$$

## 2. Current Approach for LG Structures

### 2.2 Structural Allowables Derivation

- **Torsion Modulus of Rupture  $F_{stu}$  of Round Tubes (1/5)**

- > **Overview**

- >  $F_{stu}$  is a **fictitious** stress allowable that represent the “**elastic**” shear stress level at which the torsional fracture of the tube is predicted:

$$F_{stu} = \frac{R_e}{I_o} M_{t\,ult}$$

- $R_e = D/2$  is outer/external radius of the cylinder
- $I_o$  is the polar moment of inertia
- $M_{t\,ult}$  is the ultimate torque, that is, the torque level that results in the torsional rupture of the tube

- > As  $F_{stu}$  is calculated from the elastic stress equation, a margin calculated from this value and the torsional shear stress is equivalent to calculating the margin using the applied and ultimate internal moments:

$$MoS = \frac{F_{stu}}{\sigma_{st}} - 1 = \frac{M_{t\,ult}}{M_t} - 1$$

- > The calculation of  $M_{t\,ult}$  depends upon the torsion fracture mode. One distinguishes **two different torsion fracture modes**:

- ♦ **Fracture mode for stable cylinders** (L/D=0): The tube section remains stable (no buckling), the fracture occurs by pure plastic collapse (plasticity is developed through the entire tube thickness) corresponding to global instability.
- ♦ **Fracture mode for buckled cylinders** (L/D>0): Buckling waves are developed across the tube middle surface. The fracture occurs when the maximum torque is reached for a post-buckling equilibrium state in the elastic-plastic domain.

## 2. Current Approach for LG Structures

### 2.2 Structural Allowables Derivation

- Torsion Modulus of Rupture  $F_{stu}$  of Round Tubes (2/5)

- Stable Cylinder ( $L/D = 0$ ):

- ◆ The ultimate torque  $M_{t\text{ult}}$  is derived assuming that the **complete cross-section** is subjected to the material ultimate shear stress  $F_{su}$

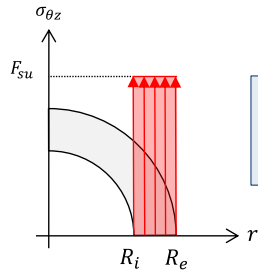

$$M_{t\text{ult}} = \int_0^{2\pi} \int_{R_i}^{R_e} r F_{su} r dr d\theta = 2\pi F_{su} \int_{R_i}^{R_e} r^2 dr$$

- ◆  $F_{stu}$  for  $L/D=0$  can therefore be readily obtained using the following formula:

$$F_{stu} = \frac{4}{3} F_{su} \frac{1 - \left(1 - 2\frac{t}{D}\right)^3}{1 - \left(1 - 2\frac{t}{D}\right)^4}$$

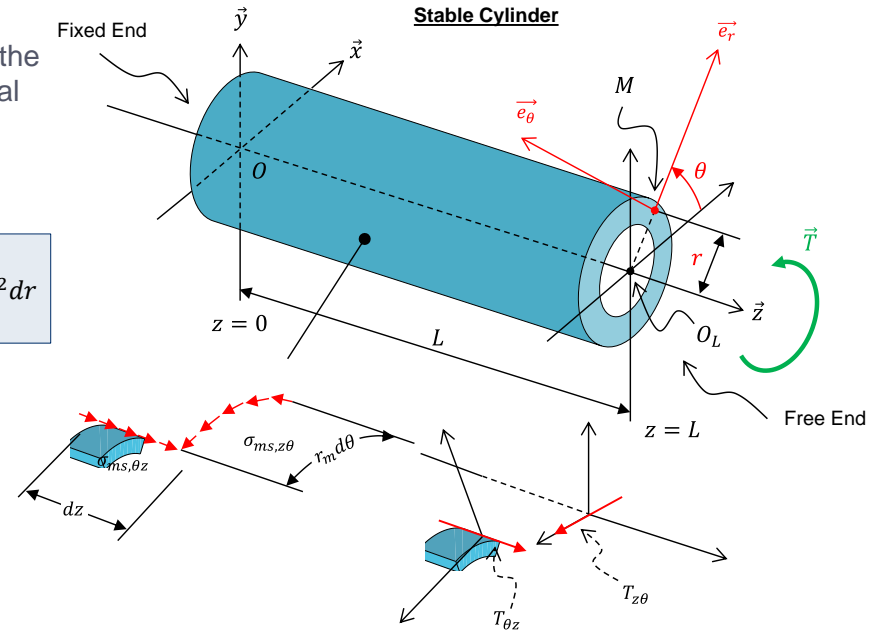

## 2. Current Approach for LG Structures

### 2.2 Structural Allowables Derivation

#### ▪ Torsion Modulus of Rupture $F_{stu}$ of Round Tubes (3/5)

##### > Buckled Cylinder ( $L/D > 0$ ):

- ♦ The state of stress in an isolated infinitesimal element is much more complex than for the case of a stable section
- ♦ The value of  $M_{t\text{ult}}$  is derived using the method of calculation published by LAWRENCE H. N. LEE and CLIFFORD S. ADES in their paper « Plastic Torsional Buckling Strength of Cylinders Including the Effects of Imperfections » (1957)
- ♦ The ADES paper is referenced in the MMPDS. The paper method of calculation was used to produce the TMoR charts published in the MMPDS.

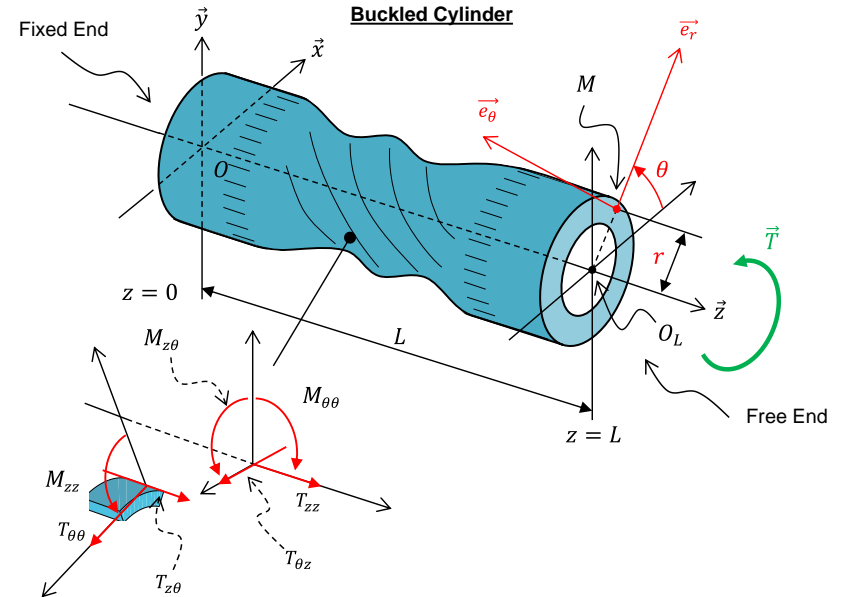

## 2. Current Approach for LG Structures

### 2.2 Structural Allowables Derivation

- Torsion Modulus of Rupture  $F_{stu}$  of Round Tubes (4/5)

- > Buckled Cylinder ( $L/D > 0$ ):

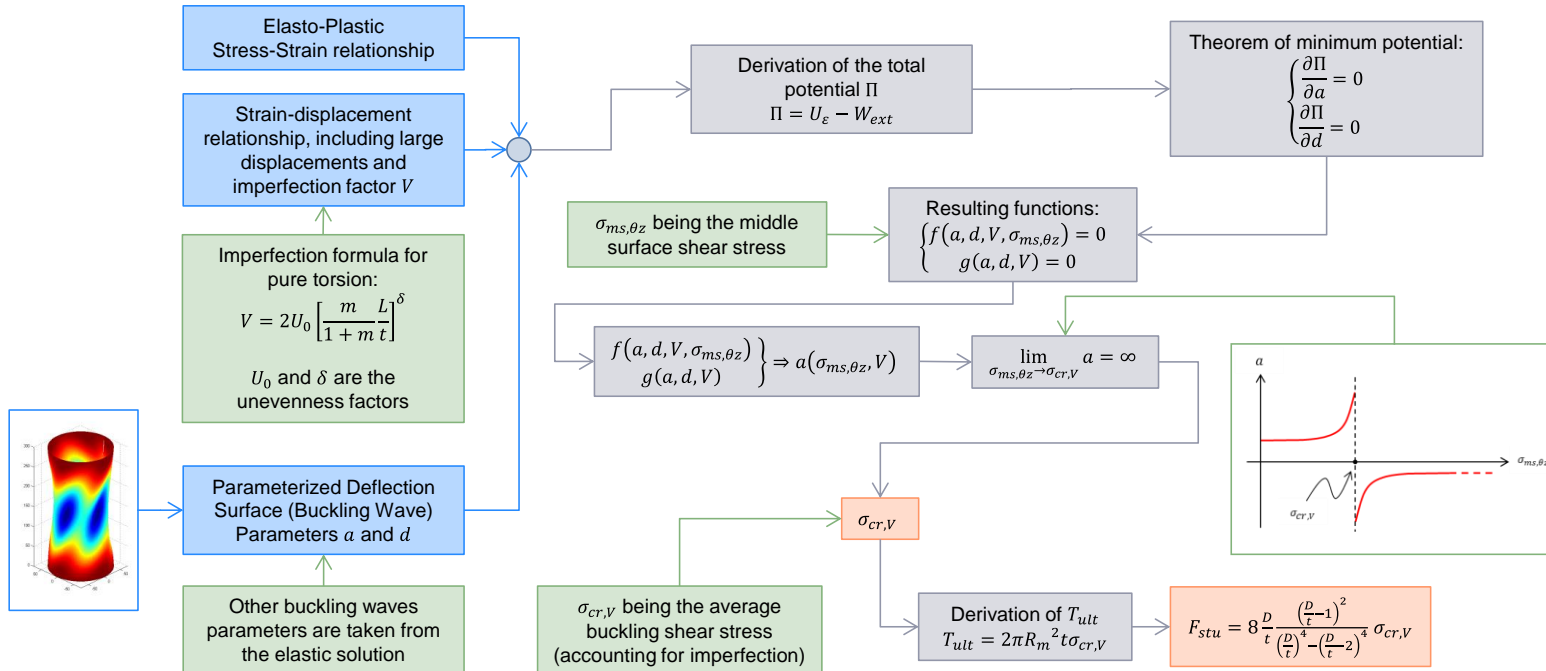



## 2. Current Approach for LG Structures

### 2.2 Structural Allowables Derivation

#### ▪ Torsion Modulus of Rupture $F_{stu}$ of Round Tubes (5/5)

##### > Method assumptions and example of TMoR charts:

- ♦ Thin shell theory involving the effects of large deflections and imperfections in the elastic-plastic domain but small strains,
- ♦ There are no normal stresses in the radial direction,
- ♦ Lines originally normal to the median surface of the shell, remain so under loading,
- ♦ The deflection shape (buckling wave) of the middle surface in the plastic range is assumed to be the same as the one of the elastic range,
- ♦ For the derivation of the internal strain energy, it is assumed that no part of the cylinder is being unloaded,
- ♦ It is assumed that material moduli,  $E_{sec}$  and  $E_{tan}$ , are independent of the circumferential position as for the middle surface shear stress  $\sigma_{ms,\theta z}$  (average) and therefore of the amplitude of the buckling wave.

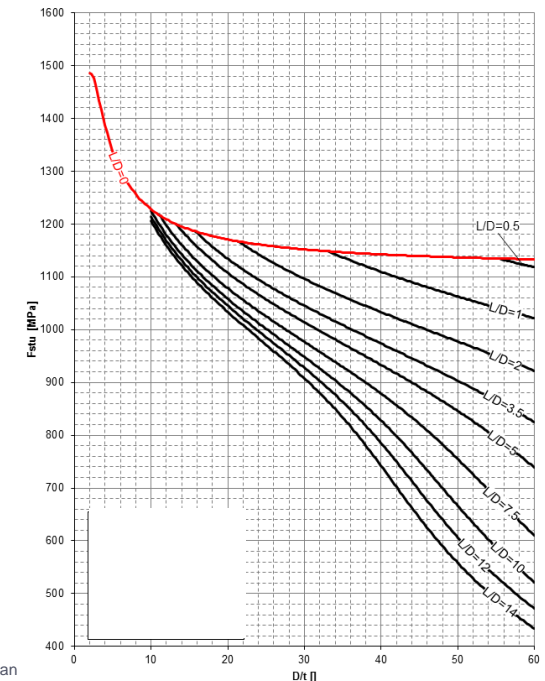
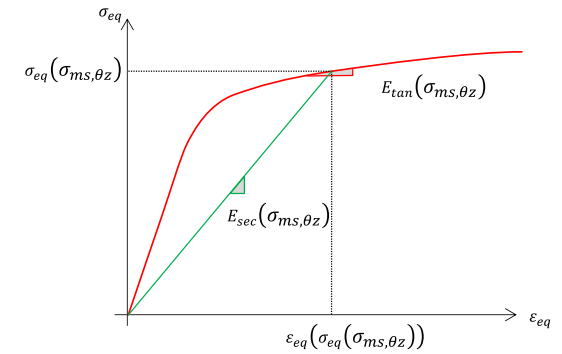

## 2. Current Approach for LG Structures

### 2.2 Structural Allowables Derivation

- Lugs (1/5)

- Axial loading: Lug rupture factors  $K_{bru}$  and  $K_{tuy}$

- ◆ Fracture of the lug under pure axial loading is determined by considering the tensile rupture mode (i) separately, and the shear tear-out rupture (ii) and bearing (iii) modes as a combined shear-bearing mode

- ◆ Net-tension rupture mode:

$$P_{tuy} = K_{tuy} F_{tuy} (w - D)t$$

- ◆ Shear-bearing rupture mode:

$$P_{bru} = K_{bru} F_{tuy} D t$$

- ◆ The minimum allowable rupture load is retained for design purposes:

$$P_{uymin} = \min(P_{tuy}, P_{bru})$$

- ◆ Lug rupture factors  $K_{tuy}$  and  $K_{bru}$  are geometric and material dependent and are obtained analytically or based on historical charts

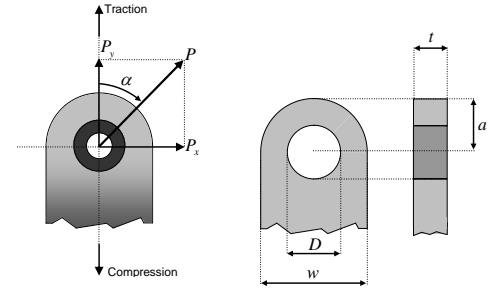
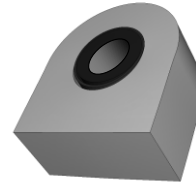

- Geometric and loading definitions for a straight lug subjected to oblique pin-load -

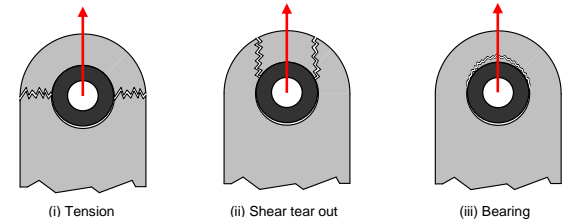

- Lug fracture modes under pure axial loading -

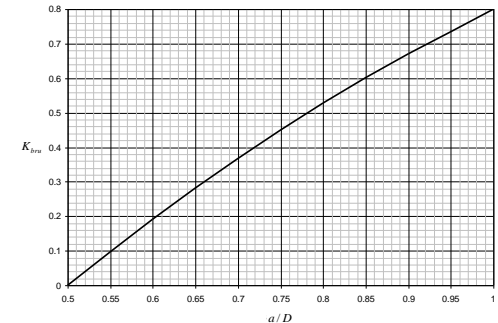
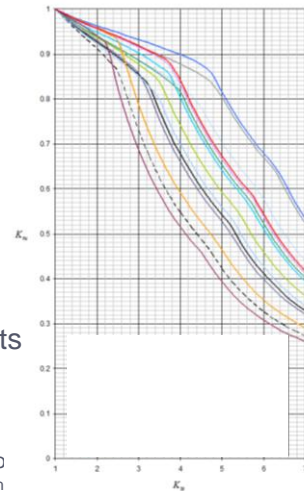

## 2. Current Approach for LG Structures

### 2.2 Structural Allowables Derivation

- Lugs (2/5)

- Axial loading: Lug rupture factors  $K_{bru}$  and  $K_{tuy}$

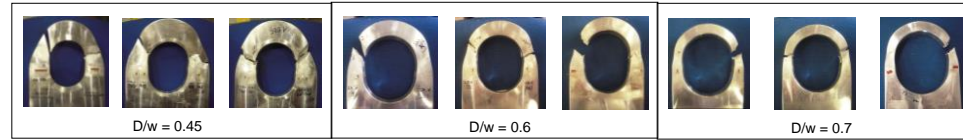

- ◆ Melcon-Cozzone-Hoblit (MCH) method is in perfect agreement with lug test results

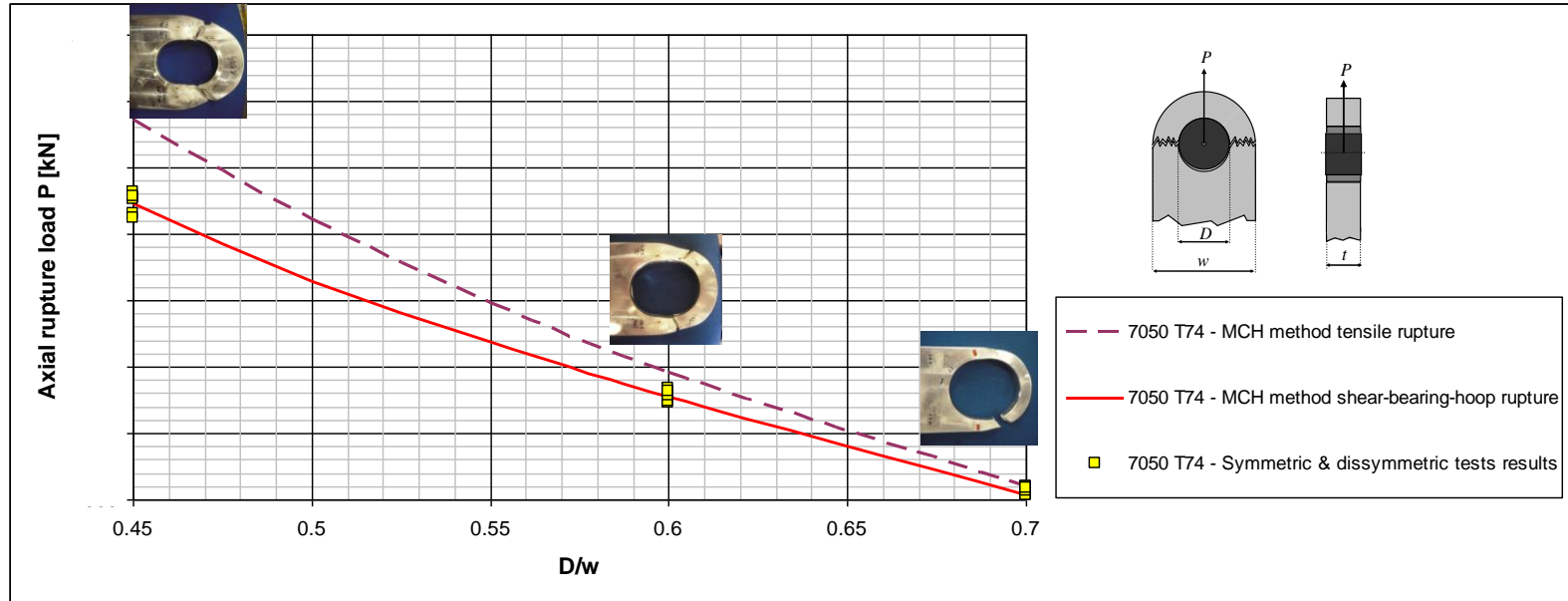

## 2. Current Approach for LG Structures

### 2.2 Structural Allowables Derivation

- Lugs (3/5)

- Transverse loading: Lug rupture factor  $K_{tru}$

- ◆ Fracture of the lug under transverse loading is determined by considering the hoop tension rupture mode (i), shear rupture (ii) and bearing rupture (iii) modes separately
    - ◆ Hoop tension rupture mode:  $K_{tru}^{hoop}$
    - ◆ Shear-bearing rupture mode:  $K_{tru}^{shear}$
    - ◆ Lug rupture factors  $K_{tru}^{hoop}$  and  $K_{tru}^{shear}$  are geometric and material dependent and are obtained analytically or based on charts
    - ◆ The minimum allowable lug rupture factor retained for design purposes:  $K_{tru} = \min(K_{tru}^{shear}, K_{tru}^{hoop})$
    - ◆ The allowable lug rupture load is  $P_{tru} = K_{tru} F_{tux} D t$

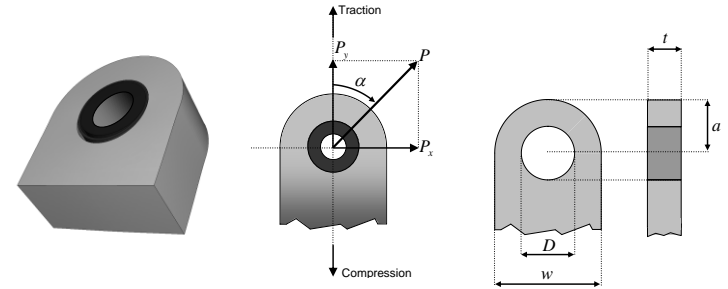

- Geometric and loading definitions for a straight lug subjected to oblique pin-load -

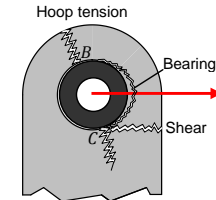

- Lug fracture modes under pure transverse loading -

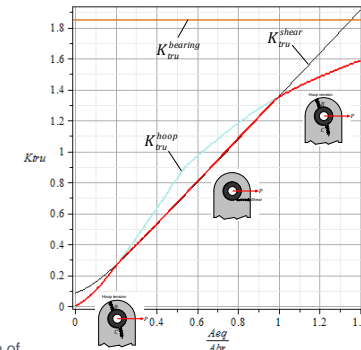

## 2. Current Approach for LG Structures

### 2.2 Structural Allowables Derivation

- Lugs (4/5)
  - > **Transverse loading:** Lug rupture factor  $K_{tru}$ 
    - ♦ Method in very good agreement with lug test results

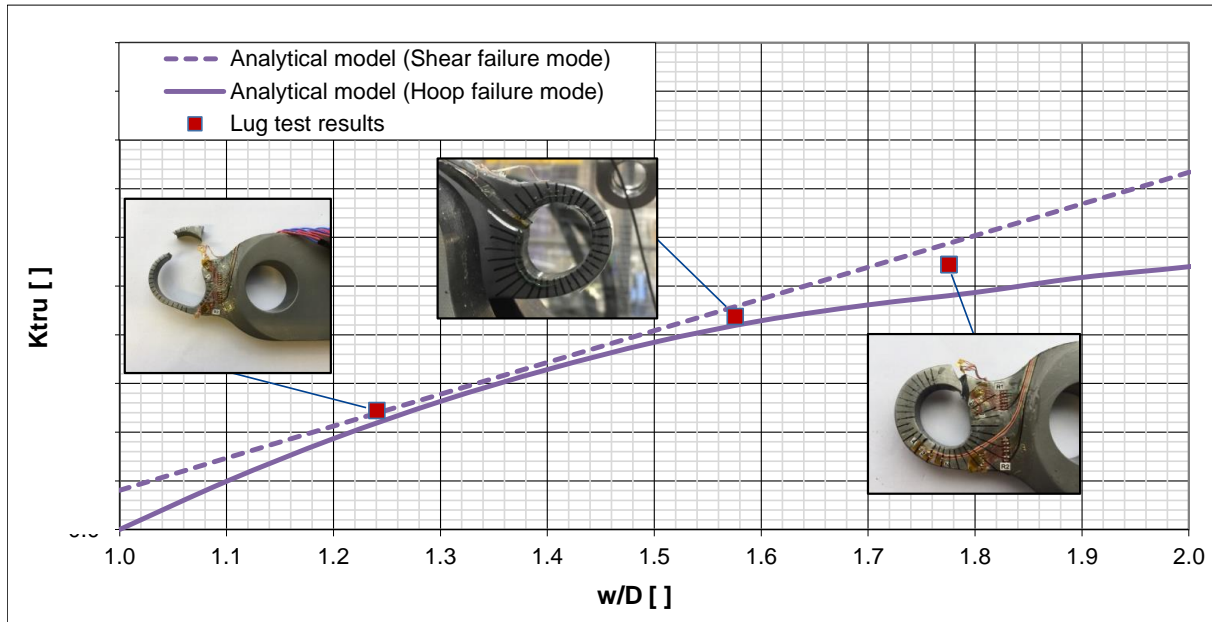

## 2. Current Approach for LG Structures

### 2.2 Structural Allowables Derivation

#### ▪ Lugs (5/5)

##### > Oblique loading: Interaction

- ♦ For the general case of an oblique loading, combinations of various fracture modes are involved
- ♦ Combination of lug allowable axial and transverse loads into an **interaction equation**:

$$U_{ult} = \left[ \left( \frac{P_{yult}}{P_{uymin}} \right)^{1.6} + \left( \frac{P_{xult}}{P_{tru}} \right)^{1.6} \right]^{0.625}$$

- ♦ The equivalent lug ultimate allowable load is:

$$U_{ult} = 1 \Leftrightarrow P_{ua} = \frac{1}{\left[ \left( \frac{\cos(\alpha)}{P_{uymin}} \right)^{1.6} + \left( \frac{\sin(\alpha)}{P_{tru}} \right)^{1.6} \right]^{0.625}}$$

- ♦ The margin of safety is:

$$MoS = \frac{1}{U_{ult}} - 1 = \frac{P_{ua}}{P} - 1 \quad \text{or} \quad MoS = \frac{|OD|}{|OA|} - 1$$

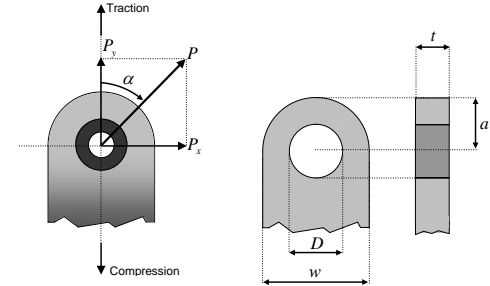
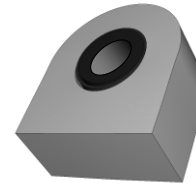

- Geometric and loading definitions for a straight lug subjected to an inclined pin-load -

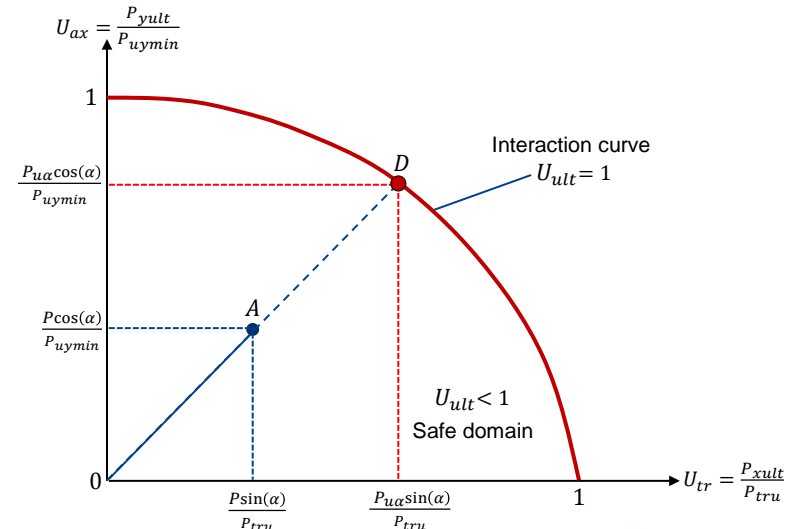

# 3

## PERSPECTIVES: TOWARDS UNIFIED RUPTURE AND INSTABILITIES CRITERIA

3.1 ENHANCEMENT OF STRUCTURAL  
ALLOWABLES DERIVATION

3.2 VIRTUAL TESTING





# 3. Towards Unified Rupture and Instabilities Criteria

## 3.1 Enhancement of Structural Allowables Derivation

- Lugs (axial or transverse loading)

➤ However adequate in practice for classical analysis, experimental observations suggest a **continuous description of the fracture phenomenon** rather than a discrete distinction of possible fracture modes, for better prediction

- ♦ Angular location  $\alpha$  of the fracture initiation and orientation  $\varphi$  of the fracture surface at this location are actually continuous functions of lug shape ratio, material parameters and relative loading eccentricity
- ♦ This can be addressed through **stability analysis** by eigenvalues/eigenvectors extraction (M. Al Kotob PhD, 2019)
- ♦ Requires a **displacement formulation** (e.g. FEM) to access the global stiffness (in lieu of current force formulation)

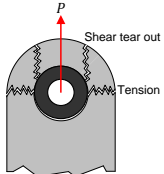

	Local Fracture Mode	Global Fracture Modes		
	Hoop Tension	Average Shear	Bearing	Global Instability
Analytical Model	$P_u$ such that $\max_{0 \leq \theta \leq 2\pi} \varepsilon_{\theta\theta}(\theta) = \varepsilon_u$	$P_u$ such that $\bar{\tau} = \frac{P_u}{A_1} = q F_{tu}$	$P_u$ such that $\sigma_{br} = \frac{P}{A_{br}} = F_{bru}$	Not addressed (stress/force formulation)
FEA	$P_u$ such that $\max_{0 \leq \theta \leq 2\pi} \varepsilon_{\theta\theta}(\theta) = \varepsilon_u$	$P_u$ such that $\bar{\tau} = \frac{P_u}{A_1} = q F_{tu}$	$P_u$ such that $\sigma_{br} = \frac{P}{A_{br}} = F_{bru}$	$P_u$ such that $[K^{TG}(\{U\})]\{\Delta U\} = \{0\}$

$$\{\alpha, \varphi(\alpha)\} = f\left(\frac{D}{w}, \{E, F_{ty}, F_{tu}, \varepsilon_u\}, \frac{e}{t}\right)$$

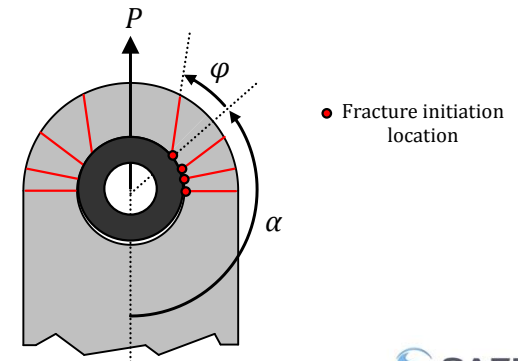

# 3. Towards Unified Rupture and Instabilities Criteria

## 3.1 Enhancement of Structural Allowables Derivation

- Lugs (low  $D/w$ ), TMoR (low  $D/t$ )
  - Finite transformations (large strains) for less conservative design criteria
  - Plastic behaviour beyond UTS

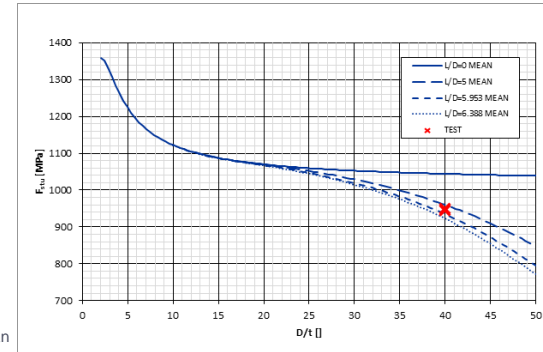
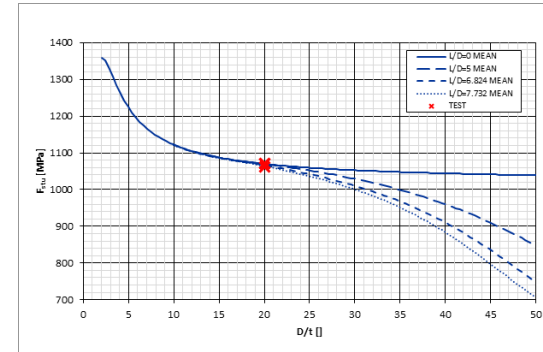
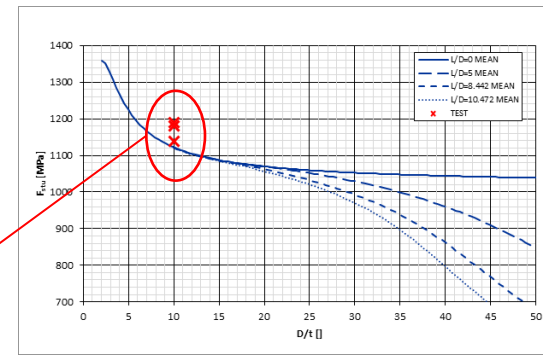
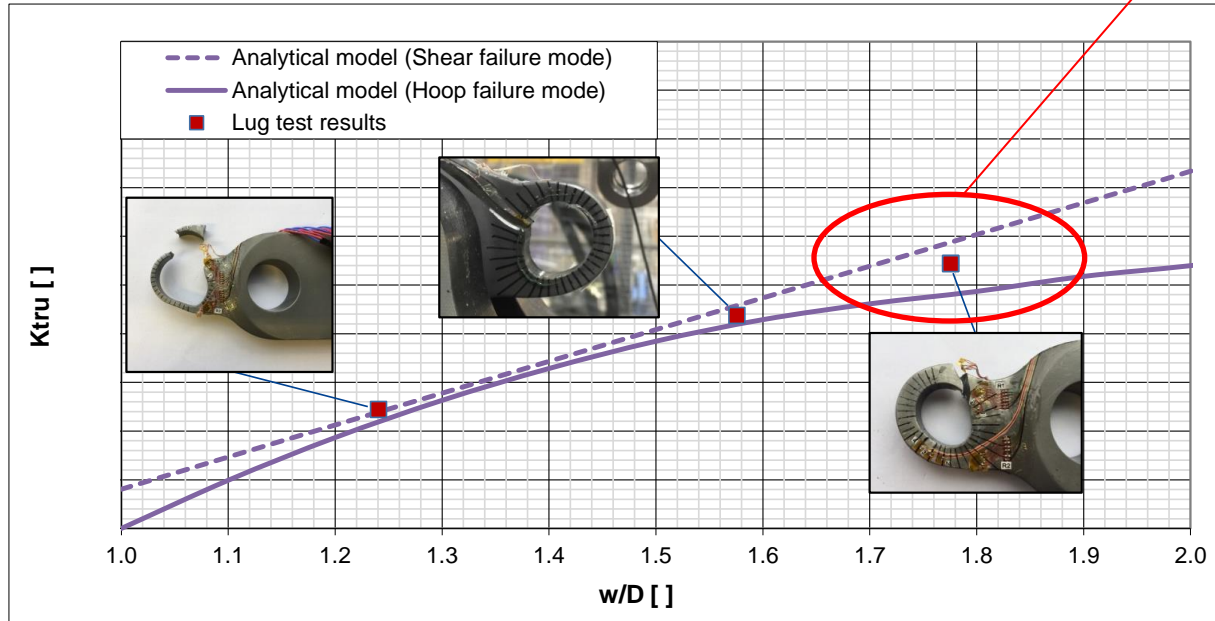

## 3. Towards Unified Rupture and Instabilities Criteria

### 3.2 Virtual Testing

- **General perspectives**

- > **Expand applicability domain of current analysis methods limited due to restrictive assumptions**

- ♦ **Less conservative** design criteria against rupture occurrence  
...while being cautious that one conservative assumption may actually cover (or hide) some other non-conservatism!
    - ♦ **More accuracy** needed to address rupture prediction (fuse parts)

- > **Support the choice (decision) of (for) new materials in stronger conjunction with structural strength analysis**

- > **Reduce the needed number of supporting tests which remain required by certification rules**



---

**Thanks for your attention!**

**Questions?**

---



**POWERED  
BY TRUST**